

R&S®FSH-Z114

Precision Frequency Reference

Service Manual



1321.2518.02 – 01

The Service Manual describes the following R&S® R&S FSH-Z114FSH-Z114 models and options:

- R&S®FSH-Z114 (1304.5935.02)

© 2012 Rohde & Schwarz GmbH & Co. KG

Muehldorfstr. 15, 81671 Munich, Germany

Phone: +49 89 41 29 - 0

Fax: +49 89 41 29 12 164

E-mail: info@rohde-schwarz.com

Internet: <http://www.rohde-schwarz.com>

Subject to change – Data without tolerance limits is not binding.

R&S® is a registered trademark of Rohde & Schwarz GmbH & Co. KG.

Trade names are trademarks of the owners.

The following abbreviations are used throughout this manual:

R&S®FSH-Z114 is abbreviated as R&S FSH-Z114

Contents

1	Documentation Overview	4
2	Performance Test	5
2.1	Test Instructions	5
2.2	Measuring Equipment and Accessories	5
2.3	Performance Test.....	6
2.4	Performance Test Report.....	7
3	Adjustment	8
4	Repair.....	9
4.1	Cable Replacement.....	9
4.1.1	List of Spare Parts	9
4.1.2	Disassembly of the R&S FSH-Z114	9
4.1.3	Connector Details	10
4.1.4	Cable Replacement	10
4.1.5	Assembly of the R&S FSH-Z114	11
4.2	Device Replacement.....	11
5	Software Update / Installing Options	12
6	Documents	13
6.1	Spare Parts	13
6.2	Block Diagram.....	14

1 Documentation Overview

The user documentation for the R&S FSH-Z114 is divided as follows:

- Operating Manual
- Service Manual

Operating Manual

This manual is available in PDF format on the CD delivered with the instrument. The printed manual can be ordered from Rohde & Schwarz GmbH & Co. KG.

The operating manual describes instrument functions, setup and software requirements for using the R&S FSH-Z114.

It includes the following chapters:

- Chapter 1 Basic safety instructions
- Chapter 2 Front View of R&S FSH-Z114
- Chapter 3 Operating R&S FSH-Z114

Service Manual

This manual is available in PDF format. It informs about how to check compliance with rated specifications, and it contains all information required for repairing the R&S FSH-Z114, for troubleshooting and fault elimination. The manual includes the following chapters:

- Chapter 1 Performance Test
Provides all the information necessary to check for compliance with rated specifications. The required test equipment is also included.
- Chapter 2 Adjustment
Describes the steps necessary for adjustment of the R&S FSH-Z114.
- Chapter 3 Repair
Describes the design as well as simple measures for repair and fault diagnosis, in particular, the replacement of spare parts.
- Chapter 4 Software Update / Installing Options
Contains information on the required firmware version.
- Chapter 5 Documents
Contains spare parts lists, exploded views and other diagrams and drawings.

Release Notes

The release notes describe the installation of the firmware, new and modified functions, eliminated problems, and last minute changes to the documentation. The corresponding firmware version is indicated on the title page of the release notes. The current release notes are provided in the Internet.

2 Performance Test

This chapter provides information on how to verify the R&S FSH-Z114 performance. It contains an overview of the required equipment, and describes the test procedure and the detailed test objectives. At the end of this chapter, templates for test reports are supplied for your convenience. Fields in the report that the user must fill out before or during the test are indicated by a gray background.

2.1 Test Instructions

- Before testing the rated specifications of the Precision Frequency Reference R&S FSH-Z114 the following conditions must be met:
 - The warm-up time specified for the R&S FSH must have elapsed.
 - The R&S FSH-Z114 must be connected to an R&S FSH as described in the operating manual.
 - The R&S FSH-Z114 oscillator must be in 'locked' state for the time period specified in the datasheet to obtain its specified frequency accuracy.
- The performance test is defined for an ambient temperature of 23°C +/- 3°C.
- Values and limits indicated in the following sections are derived from the data sheet. In case of conflicts the specifications provided in the data sheet are binding.
- Make sure to take measurement uncertainties of your test setup into account.

2.2 Measuring Equipment and Accessories

Item	Type of equipment	Specifications recommended	Equipment recommended	R&S part no.
1	Signal generator	RF = 3 GHz	R&S SMB100A R&S B103	1406.6000.02 1407.2709.02
2	10 MHz Rubidium Frequency Standard	Initial calibration accuracy $\pm 5E-11$ or better aging per year $\pm 1E-10$ or better		
3	Handheld Spectrum Analyzer		R&S FSH4 / R&S FSH8	1309.6000.04 1309.6000.08
4	RF cable	N(m) - N(m), 50 Ω DC to 3 GHz		
5	RF cable	BNC(m) - BNC(m), 50 Ω		

2.3 Performance Test

Checking the frequency accuracy

- Test equipment:
- Signal generator (see [Measuring Equipment and Accessories](#), item 1)
 - Frequency standard rubidium (see [Measuring Equipment and Accessories](#), item 2)
 - Portable spectrum analyzer (see [Measuring Equipment and Accessories](#), item 3)

- Test setup:
- ▶ Connect the Rubidium frequency standard to connector "Ext Ref In" of the signal generator.
 - ▶ Connect the signal generator RF Output to the R&S FSH RF Input.
 - ▶ Make sure that the warm-up time of the R&S FSH has elapsed
 - ▶ Connect the R&S FSH-Z114 connector cable to the "Power Sensor" connector of the R&S FSH

Signal generator settings:

Frequency:	3 GHz
Level:	-10 dBm
Reference oscillator:	External

- R&S FSH settings:
- ▶ MODE: Spectrum
 - ▶ PRESET
 - ▶ SETUP: Auto Accessory Detection: On
 - ▶ FREQ: Center: 3 GHz
 - ▶ SPAN: 20 kHz
 - ▶ MKR→: Set To Peak
 - ▶ MKR→: Center = MKR: Center + Level = Marker
 - ▶ BW: Manual RBW: 1 kHz
 - ▶ SPAN: 0 Hz
 - ▶ AMPT: Ref Level: -10 dBm
 - ▶ SWEEP: Manual SWP Time: 500 ms
 - ▶ MARKER: Marker Function: Frequency Count

Notes: Make sure that the message "FSH-Z114" is displayed in GREEN color on the R&S FSH display after turning Auto Accessory Detection on. This may take up to 3 minutes. The green message tells that the reference oscillator is locked.

Make sure that the specified time after the reference oscillator has locked has elapsed before starting the subsequent measurement.

- Measurement:
- ▶ Read the marker count result and write it down.

Note: Refer to the table in [Performance Test Report](#) for tolerances.

2.4 Performance Test Report

ROHDE & SCHWARZ	Performance Test Report	Version 1.0
Device:	R&S FSH-Z114	
Part number:	1304.5935.02	
Serial number:		
Person responsible:		
Date:		
Signature:		

Checking the frequency accuracy

Characteristic	Performance Test	Specified Min Value	Measured Value	Specified Max Value	Unit
Frequency accuracy	1.3.1	2999999997.3 or _____*)	_____	3000000002.7 or _____*)	Hz

*) The figures for the specified min./max. values indicated in the table are valid if the performance test is performed on the same day and at the same temperature as the alignment of the R&S FSH-Z114 High Precision Frequency Reference.

For any other conditions the limits change due to the specified aging and temperature drift of the device (see the data sheet for details). Therefore the figures indicated for the limits should be crossed out and replaced by the limits are calculated according to the following formulas:

Specified minimum value

$$3 \text{ GHz} \times (1 - (\text{time since last adjustment} \times \text{aging rate} + \text{temperature drift} + \text{calibration accuracy}))$$

Specified maximum value

$$3 \text{ GHz} \times (1 + (\text{time since last adjustment} \times \text{aging rate} + \text{temperature drift} + \text{calibration accuracy}))$$

3 Adjustment

NOTICE**Risk of erroneous measurement results**

Adjustment must be carried out exclusively in Rohde & Schwarz service centers, since any change can considerably affect the instrument's measurement accuracy.

Service tool

The R&S service centers have the necessary tools available for performing the alignment of the frequency accuracy for the R&S FSH-Z114.

4 Repair

The following chapter describes how to replace cable for R&S FSH-Z114.

4.1 Cable Replacement

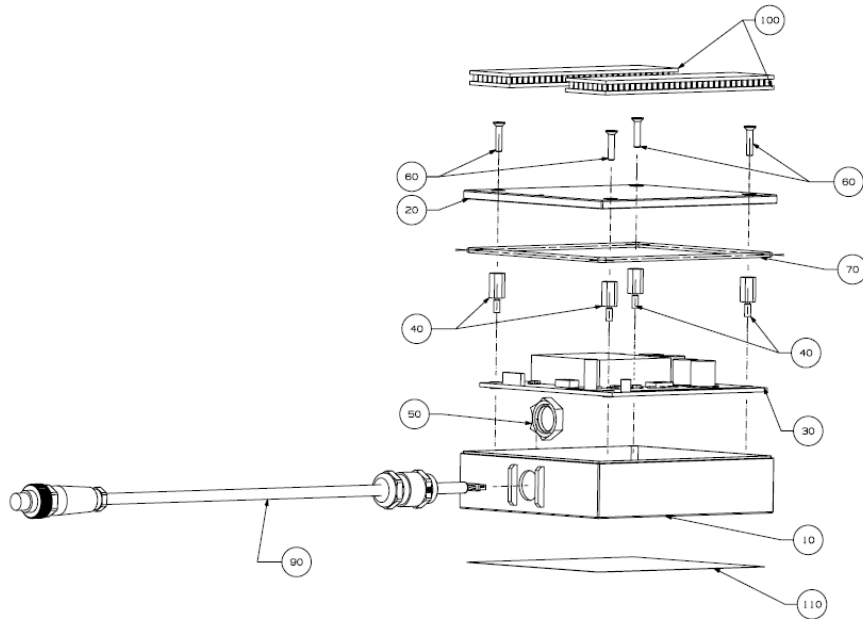

Figure 4-1: Mechanical assembly drawing

4.1.1 List of Spare Parts

For the list of available spare parts refer to [Spare Parts](#).

4.1.2 Disassembly of the R&S FSH-Z114

4.1.2.1 Required Tools

- TORX screwdriver size 8

4.1.2.2 Opening the R&S FSH-Z114

1. Remove the velcro tape (pos. 100).
2. Unscrew the top cover screws (pos. 60).
3. Remove the top cover (pos. 20).

4.1.3 Connector Details

Pos	Designation	Connector inside the device (pin #)	Binder connection (pin #)	Remarks
1	+5V	1	1	
2	RF Out	2	3	
3	1 PPS	3	2	
4	GND	4	4	
5	TXD	5	5	
6	RXD	6	6	
			7	Pin 7 and 1 Shorted

Table 4-1: Connector cable assignment

4.1.4 Cable Replacement

4.1.4.1 Required Tools

- TORX screwdriver size 8
- Spanner size 18 mm

4.1.4.2 Troubleshooting the Cable

4. Open the device (see [Opening the R&S FSH-Z114](#))
5. Check whether the contact from the connector inside the device to the corresponding pins at outside the binder connector is ok.
6. If the cable is found defective, replace the cable (pos. 90).
7. Remove nut (pos. 50)
8. Replace cable (pos. 90)
9. Tighten the nut (pos. 50)
10. Assemble the device (see [Assembly of the R&S FSH-Z114](#))

4.1.5 Assembly of the R&S FSH-Z114

11. Assemble the Device in reverse order as described in [Disassembly of the R&S FSH-Z114](#).
12. Insert the sealing (pos. 70)
13. Assemble the top cover (pos. 20)
14. Tighten the top cover screws (pos. 60)
15. Attach the new velcro tape (pos. 100) as shown below (area highlighted in red).

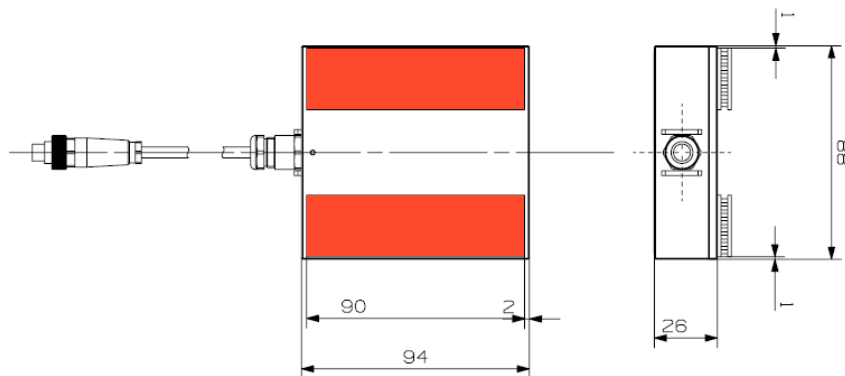

Figure 4-2: Velcro tape position

4.2 Device Replacement

If the cable is found in good conditions and the device is still not working, a one to one replacement of the device is recommended.

5 Software Update / Installing Options

Use R&S FSH firmware version 2.12 or higher in combination with the R&S FSH-Z114 option.

6 Documents

This chapter provides information on ordering of spare parts and contains the spare part list and the documents for the complete R&S FSH-Z114 unit.

6.1 Spare Parts

The stock numbers necessary for ordering replacement parts and modules can be found in the spare part list further down.

NOTICE**Risk of damaging a module**

When shipping a module, observe the instructions provided in the section titled "Procedure in Case of Service and Ordering of Spare Parts" at the beginning of this document.

Spare part list

No.	Designation	Stock no.	Quantity	Recommended spare parts
1	R&S FSH-Z114	1304.5935.02	1	
2	CABLE 7P	1309.7407.00	1	x
3	VELCRO TAPE	1309.7365.00	2	x

Table 6-1: Spare part list

6.2 Block Diagram

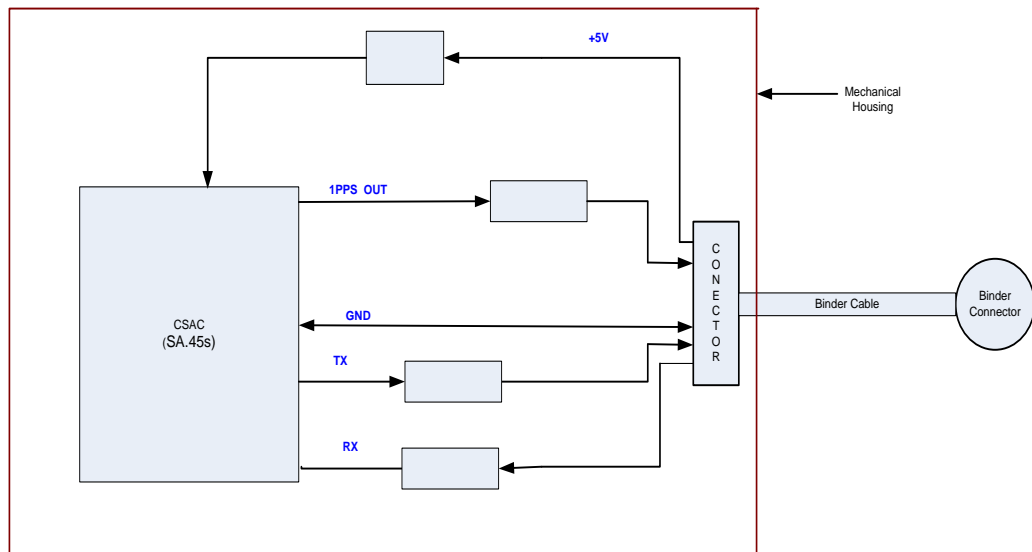

Figure 6-1: Block diagram of the R&S FSH-Z114